

This article was downloaded by:

On: 26 January 2011

Access details: *Access Details: Free Access*

Publisher *Taylor & Francis*

Informa Ltd Registered in England and Wales Registered Number: 1072954 Registered office: Mortimer House, 37-41 Mortimer Street, London W1T 3JH, UK



Liquid Crystals

Publication details, including instructions for authors and subscription information:

<http://www.informaworld.com/smpp/title~content=t713926090>

Director orientation of a ferroelectric liquid crystal on substrates with rubbing treatment: The effect of surface anchoring strength

T. Uchida^a; M. Hirano^a; H. Sakai^a

^a Department of Electronic Engineering, Faculty of Engineering, Tohoku University, Sendai, Japan

To cite this Article Uchida, T. , Hirano, M. and Sakai, H.(1989) 'Director orientation of a ferroelectric liquid crystal on substrates with rubbing treatment: The effect of surface anchoring strength', *Liquid Crystals*, 5: 4, 1127 – 1137

To link to this Article: DOI: 10.1080/02678298908026417

URL: <http://dx.doi.org/10.1080/02678298908026417>

PLEASE SCROLL DOWN FOR ARTICLE

Full terms and conditions of use: <http://www.informaworld.com/terms-and-conditions-of-access.pdf>

This article may be used for research, teaching and private study purposes. Any substantial or systematic reproduction, re-distribution, re-selling, loan or sub-licensing, systematic supply or distribution in any form to anyone is expressly forbidden.

The publisher does not give any warranty express or implied or make any representation that the contents will be complete or accurate or up to date. The accuracy of any instructions, formulae and drug doses should be independently verified with primary sources. The publisher shall not be liable for any loss, actions, claims, proceedings, demand or costs or damages whatsoever or howsoever caused arising directly or indirectly in connection with or arising out of the use of this material.

Director orientation of a ferroelectric liquid crystal on substrates with rubbing treatment: the effect of surface anchoring strength

by T. UCHIDA, M. HIRANO and H. SAKAI

Department of Electronic Engineering, Faculty of Engineering, Tohoku University, Sendai 980, Japan

One of the most important problems with ferroelectric liquid crystals is obtaining homogeneous as well as bistable alignment, not only to study their physical characteristics but also for their application to optical devices. In this connection it was predicted that the formation of homogeneous alignment requires strong surface anchoring, whereas bistability requires weak anchoring. We have therefore developed a method to determine the surface anchoring strength, and have tried to clarify whether there is a suitable anchoring range. It was found that A/K_{22} (A is the surface anchoring and K_{22} is the twist elastic constant of liquid crystal) of 4×10^{-2} to $2 \mu\text{m}^{-1}$ satisfies the contradictory requirements for homogeneous as well as bistable alignments for the material studied, and the bookshelf structure is successfully formed with this condition.

1. Introduction

Ferroelectric liquid crystals have become of major interest for applications to display devices and various optoelectronic devices, as well as of physical interest because of their features of their fast response and memory characteristics [1]. However, one of the most important problems with these materials is obtaining homogeneous and/or bistable alignment. A practical method of obtaining homogeneous alignment for a conventional liquid crystal is rubbing, although the optimum rubbing condition for the ferroelectric liquid crystals has not yet clarified in terms of alignment uniformity, reproducibility and stability. Therefore, in this paper we discuss the mechanism of homogeneous alignment of such a material, particularly in relation to the surface anchoring strength.

2. Experiment and discussion

Glass substrates used in the experiment on the liquid crystal orientation were treated as follows:

- (1) dipping in 5 wt % aqueous solution of polyvinyl alcohol (degrees of saponification 86.5-89 mol %, polymerization grade 500; Kanto Chemical Co., Inc.);
- (2) drying, followed by heat treatment (at 130°C for 15 min);
- (3) rubbing with a cloth.

The ferroelectric liquid crystal used in the experiment was CS-1011 (Chisso Corporation), which has a chiral nematic (N^*) phase and smectic A (S_A) phase above the chiral smectic C (S_C^*) phase.

As for the homogeneous alignment of ferroelectric liquid crystals, it is known empirically that the use of a liquid crystal with the phase sequence isotropic (I)- N^* - S_A - S_C^* combined with the gradual decrease of temperature from the isotropic to the

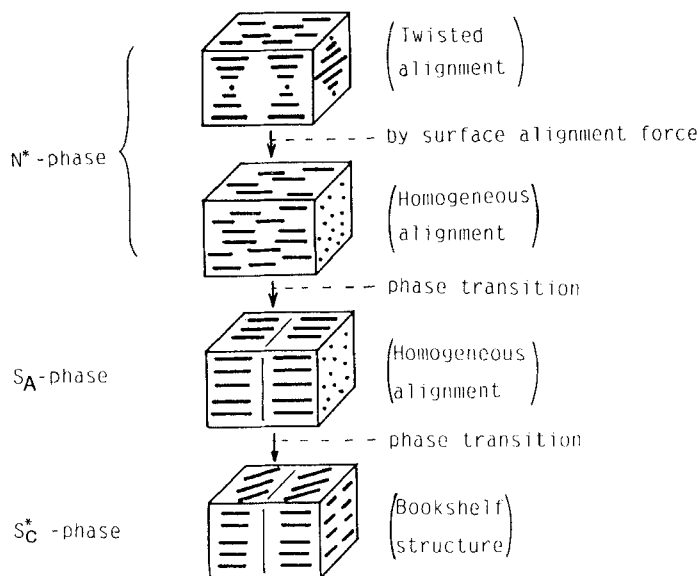

Figure 1. The formation process for homogeneous alignment of the ferroelectric liquid crystal.

chiral smectic C phase is effective to obtain better alignment. These facts reveal that the formation of homogeneous alignment (i.e. the bookshelf structure) of ferroelectric liquid crystals proceeds according to the following steps (see figure 1):

- (1) homogeneous alignment of the N* phase;
- (2) smectic layer is formed perpendicular to the surface at the transition to S_A;
- (3) the smectic layer is maintained and the bookshelf structure is formed at the transition to S_C.

Of these, steps (1) and (3) are known to be difficult, in general. We have therefore emphasized the investigation of these two steps and we discuss them separately.

2.1. Homogeneous alignment in the N* phase

Molecular alignment in the N* phase was investigated by using a Cano wedge cell, as shown in figure 2, the substrate surface was treated as described in the previous section. As is well known, distribution of the molecular alignment in this cell is discrete and disclination lines appear at the boundaries as shown in figure 2. Here, homogeneous alignment occurs in the thinnest region, and the upper limit of the cell gap of this region is $d(D_1)$, as shown in figure 2; this is equal to $P_0/4$ (P_0 is the natural pitch) in the equilibrium state. In the cooling process, however, P_0 increases with decreasing temperature, so $d(D_1)$ increases according to P_0 , as shown by the full line in figure 3. Further, if the cooling rate is increased too much, then the increase of $d(D_1)$ becomes unable to follow it and deviates from $P_0/4$ as shown by the broken line in the same figure. Then, when the temperature reaches to the N*-S_A transition the alignment is frozen in. Therefore, $d(D_1)$ at the transition, d_a , indicates the largest cell-gap to give homogeneous alignment.

Next, the effect of the surface anchoring strength on the liquid crystal alignment was examined. Figure 4(a) shows the temperature dependence of $d(D_1)$ as a function

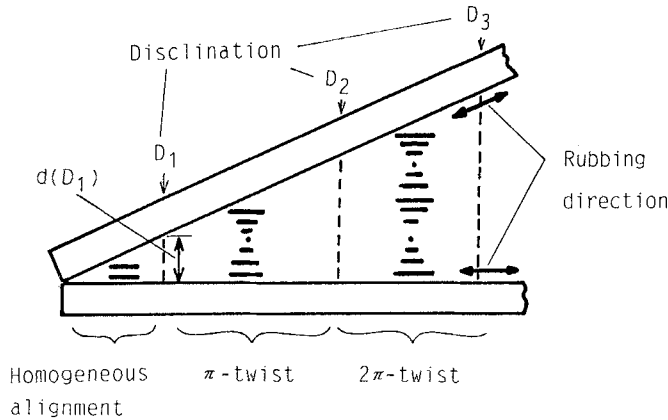

Figure 2. Director alignment in the Cano wedge cell.

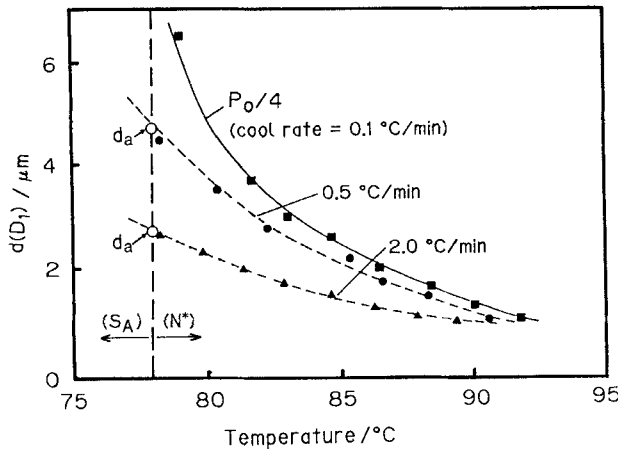

Figure 3. Temperature dependence of $P_0/4$ and $d(D_1)$ for various cooling rates.

of the cumulative number of rubbings for a cooling rate of $0.5^\circ\text{C min}^{-1}$. It is seen from this figure that d_a decreases as the cumulative number of rubbings decreases; this is shown directly in figure 4(b). The reason for this can be explained as follows. The weaker the surface anchoring, the larger the deviation of the molecular orientation is from the rubbing direction, which decreases the bulk twist elastic energy and hence decreases the force needed to shift the disclination to its equilibrium position (see figure 5). Therefore, d_a becomes smaller according to a decrease of the surface anchoring strength.

Here we evaluate the rubbing strength quantitatively, and clarify its relation to the surface anchoring strength. It is predicted that the rubbing strength, R_s , is a function of the rubbed density by the fibres of the rubbing cloth:

$$R_s = \gamma L, \tag{1}$$

where γ is a coefficient related to the rubbing pressure, the fibre density of the rubbing cloth, the coefficient of friction, etc., and L is the total length of the rubbing cloth which contacts a certain point of the substrate. It is given by

$$L = Nl \left(1 + \frac{2\pi rn}{60v} \right), \tag{2}$$

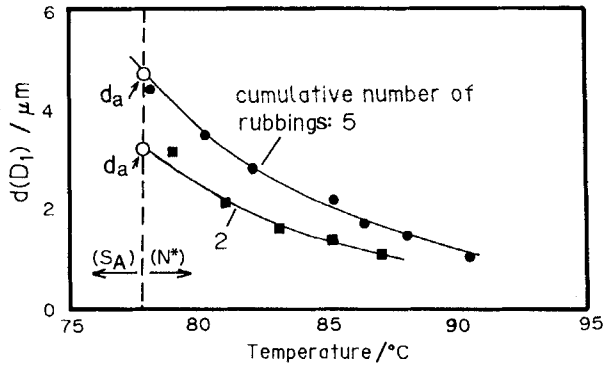

(a)

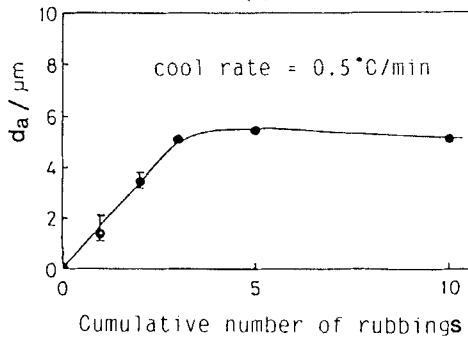

(b)

Figure 4. The effect of the cumulative number of rubbings, N , on the homogeneous alignment; (a) for $d(D_1)$ and (b) for d_a .

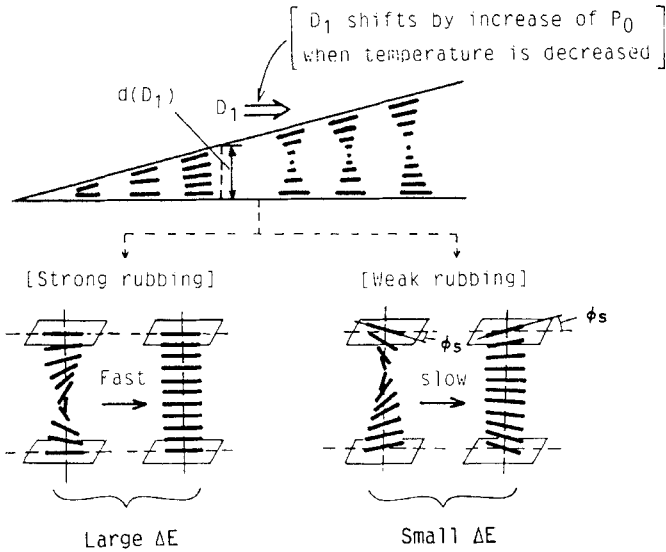

(ΔE : Difference of free energy between the two states when $d(D_1) \approx P_0/4$)

Figure 5. The effect of the rubbing strength on the promotion force to shift disclinations to their equilibrium positions.

where N is the cumulative number of rubbings, l is the contact length in circumference of the rubbing roller, n is the number of revolutions per minute (r.p.m.) of the roller, r is its radius and v is the speed of the substrate stage, as shown in figure 6. In equation (1), γ is difficult to define but L can be defined definitely, so we have defined L to be the rubbing parameter when the rubbing pressure and rubbing cloth are fixed. The validity of the definition of L is confirmed by the experimental results shown in figure 7, where d_a is plotted as a function of L when N and n are changed individually.

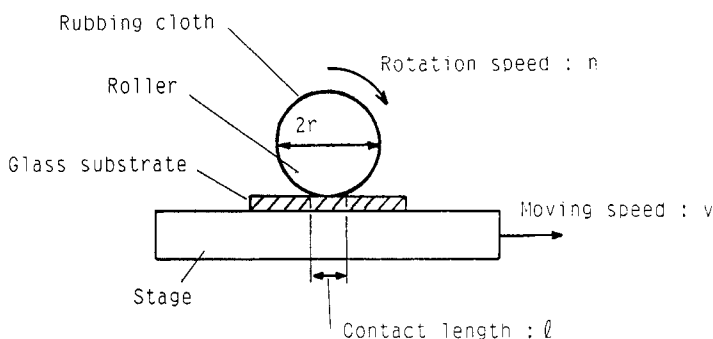

Figure 6. The definition of the parameters associated with rubbing.

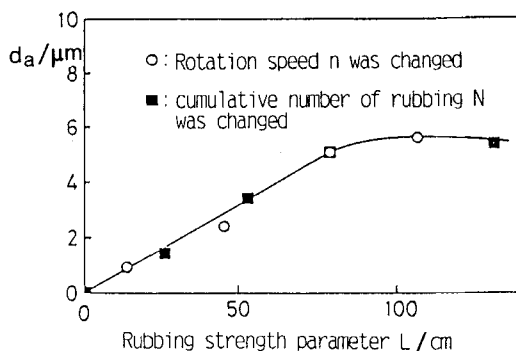

Figure 7. Relation between d_a and the rubbing strength parameter, L , when n and N are changed independently (cooling rate $0.5^\circ C \text{ min}^{-1}$, $v = 0.25 \text{ cm s}^{-1}$).

Next, we have tried to evaluate the rubbing strength in terms of the anchoring strength. The principle of measurement is as follows. When a chiral nematic is introduced into the cell whose substrates have been rubbed in the antiparallel or parallel direction, the free energy per unit area is [2]

$$F = \frac{1}{2} K_{22} \left(\frac{\psi}{d} - \frac{2\pi}{P_0} \right)^2 d + A \sin^2 \phi_s, \quad (3)$$

where K_{22} is the twist elastic constant, P_0 is the natural pitch, d is the cell gap, A is the surface anchoring strength, ϕ_s is the deviation of director at the surface from the rubbing direction and ψ is the twist angle of the director in the cell, as shown in figure 8, and is related to ϕ_s by

$$\psi = n\pi + 2\phi_s, \quad n = \text{integer}. \quad (4)$$

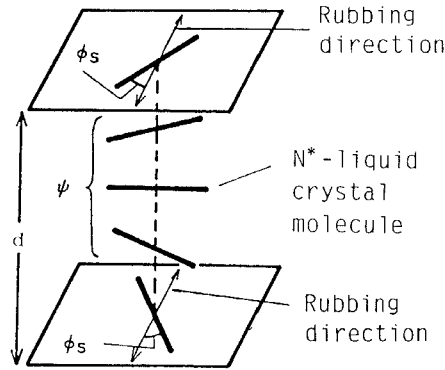

Figure 8. Definition of the director angles ϕ_s and ψ .

The first term of equation (3) corresponds to the elastic energy and the second term to the surface anchoring energy. The director orientation in this cell is obtained by minimizing F , or $\delta F/\delta\phi_s = 0$, which gives the torque balance equation as

$$K_{22} \left(\frac{2\pi}{P_0} - \frac{\psi}{d} \right) = \frac{1}{2} A \sin 2\phi_s. \quad (5)$$

From this the surface anchoring strength reduced by twist elastic constant, A/K_{22} , is

$$\frac{A}{K_{22}} = \frac{2}{\sin 2\phi_s} \left(\frac{2\pi}{P_0} - \frac{m\pi + 2\phi_s}{d} \right), \quad (6)$$

where m is integer. Here, at the edge of homogeneous alignment region or the neighbourhood of the first disclination line of the Cano wedge cell, equation (6) can be rewritten by substituting $P_0 = 4d$ and $m = 0$, to give

$$\begin{aligned} \frac{A}{K_{22}} &= \frac{\pi - 4\phi_s}{d \sin 2\phi_s} \\ &= \frac{\pi - 2\phi_s}{d \sin \psi}. \end{aligned}$$

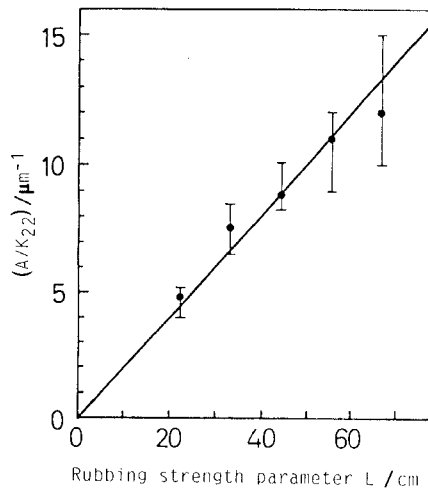

Figure 9. The dependence of the ratio A/K_{22} on the rubbing strength parameter, L .

It is seen from this equation that A/K_{22} can be determined if the cell gap and twist angle at the first disclination are known. We measured the distribution of the cell gap in the Cano wedge cell by optical interference before the introduction of the liquid crystal, and determined the value of ψ through optical rotation, using two polarizers. The results obtained for A/K_{22} of various samples are plotted in figure 9 as a function of the rubbing strength parameter, L . It is seen from this figure that A/K_{22} is proportional to L , and hence the surface anchoring strength can be controlled precisely by the parameter L .

3. Formation of the bookshelf structure in the chiral smectic C phase

It is assumed in this section that the homogeneous alignment in the N^* and S_A phases has already been attained as a precondition for discussing the formation of the bookshelf structure in the S_C^* phase. Clark and co-workers [3–5] have clarified, however, that even if the homogeneous alignment is obtained in the S_A phase, the S_C^* phase forms a chevron structure with bent smectic layers, which causes the generation of zig-zag domains and a decrease in the effective switching angle between bistable alignments. We have considered the origin of the formation or the stability of the chevron structure to be related to strong surface anchoring because this structure is favourable to fix the surface molecules. Therefore, strong anchoring was considered to prevent the formation of the bookshelf structure. In connection with this problem, it was predicted that the bistability of the molecular orientation also requires weak anchoring. On the other hand, the surface anchoring strength must be sufficiently high to obtain homogeneous alignment in the N^* phase, as mentioned in §2. Thus, conflicting conditions are required for the surface anchoring strength, so we tried to find whether there is a suitable range which satisfies both requirements.

For the first, we analysed the molecular alignment of the initial state just after the transition from a homogeneous S_A phase to the S_C^* phase. In the analysis the alignment was observed with a microscope, and the orientational direction in the azimuth was determined by measuring the direction of optical extinction between two polarizers. It was found that zig-zag domains or a modification of them were observed for almost all samples, regardless of the anchoring strength, and that the switching angle was only about 14° instead of the 38° which was expected from the tilt angle of this liquid crystal at 23°C .

Next, a square-wave voltage (typically ± 20 V, 500 Hz) was applied to this initial state and the alignment was then analysed after removal of the voltage. Figure 10 shows the orientation of the binary memory states as well as the applied voltage states as a function of the ratio A/K_{22} , where the applied voltage was a bipolar pulse voltage of ± 20 V, 1 ms width, as shown in figure 11 (a). It is seen from figure 10 that in the strong anchoring region ($A/K_{22} \gtrsim 2 \mu\text{m}^{-1}$), the orientations in the memory states are $\pm 7^\circ$, which is much smaller than those in the voltage applied states ($\pm 19^\circ$). On the other hand, in the weak anchoring region ($4 \times 10^{-2} \mu\text{m}^{-1} \lesssim A/K_{22} \lesssim 2 \mu\text{m}^{-1}$), the orientations in the memory state coincide with those in the applied voltage states. Here the lowest limit of A/K_{22} , $4 \times 10^{-2} \mu\text{m}^{-1}$, indicates that the homogeneous alignment in the S_A phase could not be obtained for lower values. Figures 11 (b) and (c) show the optical response properties for the cells with strong and weak anchoring, respectively. The latter cell is confirmed to have ideal memory states without change in contrast after removal of the applied voltage. Figures 12 (a) and (b) show photographs of the cells with strong and weak anchoring, respectively, in the memory state

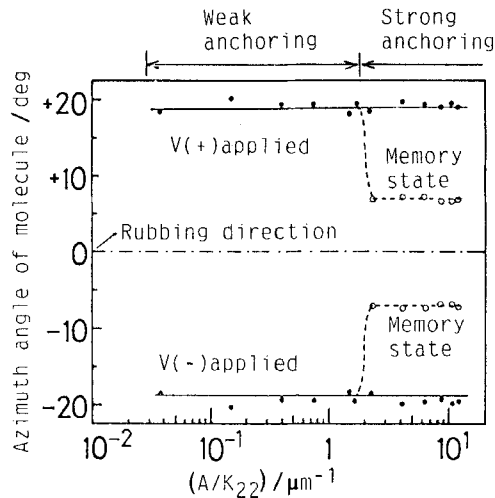

Figure 10. Director orientation in the ferroelectric liquid crystal cell as a function of A/K_{22} .

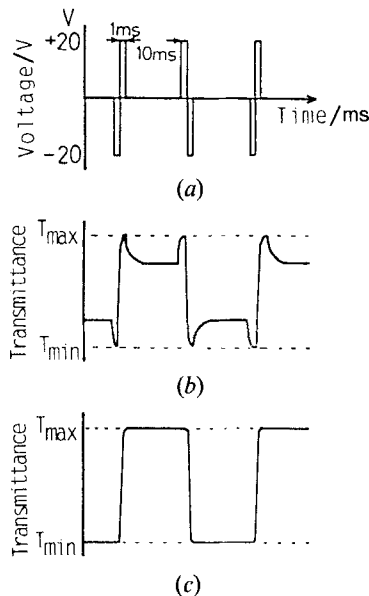

Figure 11. Optical response of the ferroelectric liquid crystal cell with strong and weak anchoring. (a) Applied voltage. (b) Strong anchoring. (c) Weak anchoring.

after application of a square voltage of ± 20 V, 500 Hz. Zig-zag domains are observed for the cell with strong anchoring, as shown in figure 12(a), but homogeneous alignment without domains is attained for the cell with weak anchoring, as shown in figure 12(b).

Based on these experimental results, the molecular orientational model is proposed as follows.

- (a) The strongly anchored cells have a chevron structure, as shown in figure 13(a), by which the existence of zig-zag domains can be explained as boundary lines

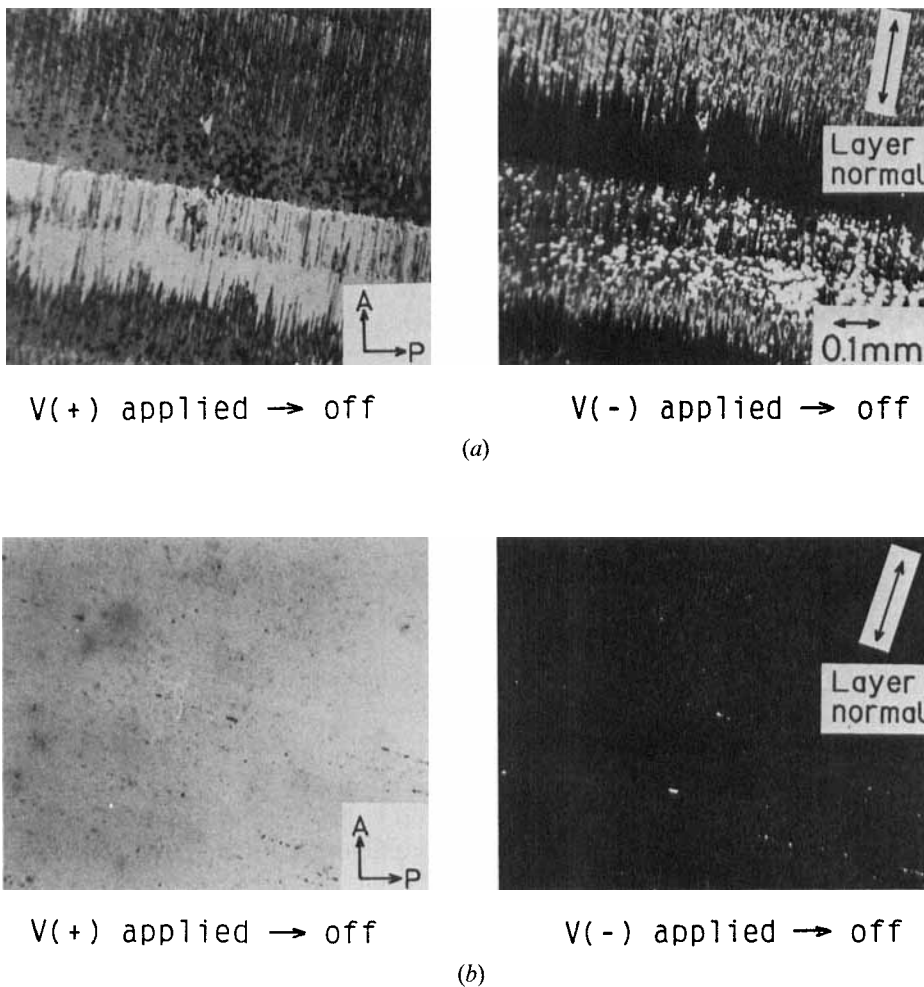

Figure 12. Photomicrograph of the ferroelectric liquid crystal cells with (a) strong anchoring (zig-zag domains) and (b) weak anchoring (domain free).

of the two different bend structures of the smectic layers as reported by Clark and Rieker [5].

- (b) The cells with weak anchoring can change their structure from the chevron to the bookshelf, as shown in figure 13 (b), by application of a square voltage. The zig-zag domain-free alignment and ideal memory property can be explained by the formation of the bookshelf structure.
- (c) The cells with strong anchoring cannot change their chevron structure by application of a square voltage, because the orientations of the surface molecules are almost fixed to the rubbing direction.

The role of the square voltage in (b) is considered to stretch the bending layer by the polarization P_s combined with the electric field. This idea is confirmed by the fact that liquid crystals with higher P_s have a stronger tendency to form the bookshelf structure. The detailed mechanism is under investigation and the results will be reported in the near future.

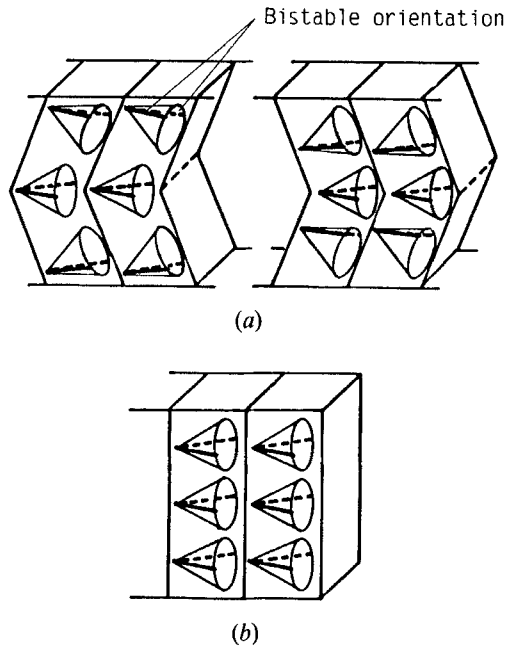

Figure 13. (a) Chevron and (b) bookshelf structures of the ferroelectric liquid crystal cell and its director organization.

4. Conclusion

In order to realize homogeneous alignment (i.e. the bookshelf structure) in the S_C^* phase, it is necessary to obtain homogeneous alignment in the N^* phase. For this purpose surface anchoring must be sufficiently strong and/or the cooling rate must be sufficiently low to increase the upper limit of the cell gap for homogeneous alignment, d_a , to be larger than the actual cell gap. On the other hand, bistable alignment was considered to require weak anchoring, so a method of measuring surface anchoring strength was developed, and the anchoring strength of rubbed substrates was determined with this method. As the results show, the anchoring strength is proportional to the newly defined rubbing strength parameter, L .

The molecular alignment and switching properties of ferroelectric liquid crystal cells with various anchoring strengths which were controlled by this method were investigated. The results show that the bookshelf structure in the S_C^* phase was obtained by extremely weak rubbing as well as by the application of a square voltage. A typical value of the ratio of the anchoring strength to the twist elastic constant, A/K_{22} was 4×10^{-2} to $2 \mu\text{m}^{-1}$ for the material studied. The ferroelectric liquid crystal cell with bookshelf structure has no zig-zag domains and reveals a large switching angle in the memory state which is almost equal to twice the tilt angle.

The authors express their hearty thanks to Professor Tatsuo Higuchi for his valuable advice and support.

References

- [1] CLARK, N. A., and LAGERWALL, S. T., 1980, *Appl. Phys. Lett.*, **36**, 899.
- [2] SHENG, P., 1974, *RCA Rev.*, **35**, 408.

- [3] CLARK, N. A., and LAGERWALL, S. T., 1986, *Proc. Japan Display*, p. 456.
- [4] RIEKER, T. P., CLARK, N. A., SMITH, G. S., PARMAR, D. S., SAFINYA, C. R., and SIROTA, E. B., 1987, 03, *1st International Symposium on Ferroelectric Liquid Crystals*, Bordeaux.
- [5] CLARK, N. A., and RIEKER, T. P., 1987, 04, *1st International Symposium on Ferroelectric Liquid Crystals*, Bordeaux; 1988, *Phys. Rev A*, p. 1053.